

1" x 3/16" SLOT SPACED EVERY 6 3/8"
(THESE TOLERANCES ARE ±1/16")

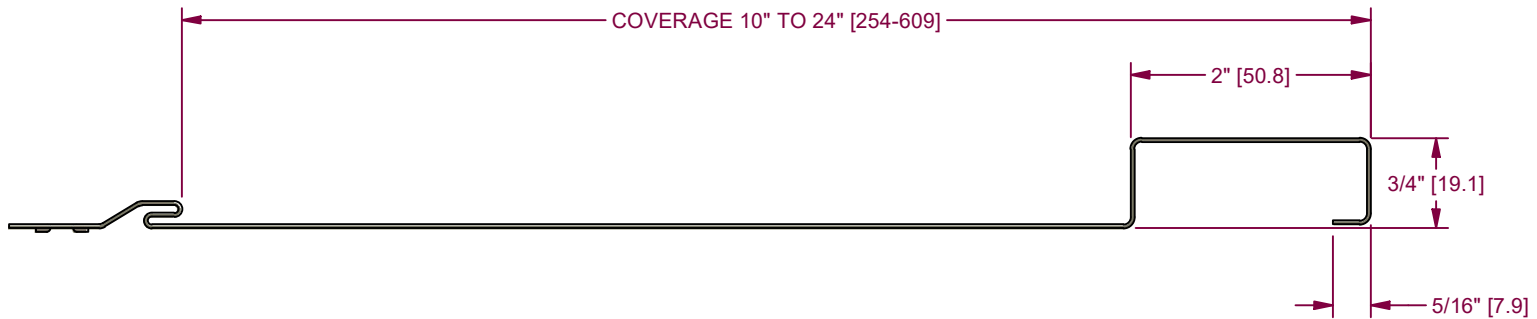
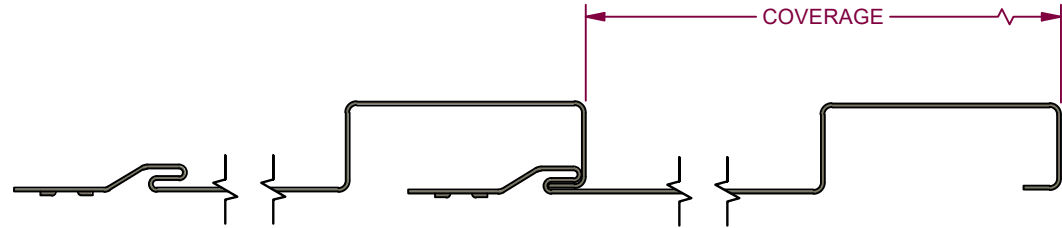
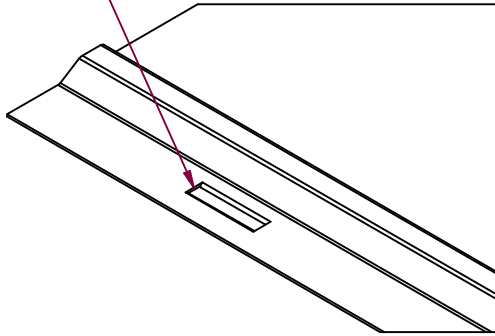

NOTES:

1. MATERIAL USAGE = 3 5/8" APPROX.
2. MATERIALS FORMED:
 - 26GA AND 24GA GRADE 50 STEEL
 - .027" AND .032" ALUMINUM

3. DIMENSIONS IN BRACKETS ARE mm AND ARE PROVIDED FOR REFERENCE ONLY.



MATERIAL				FINISH		New Tech Machinery A MAZZELLA COMPANY	
SEE NOTE							
REVISION HISTORY	REV	ECR NO.	DATE	RELEASED BY	TOLERANCES	DRAWN BY	PART NAME
	1	NONE	2/28/2023	AJB	.XX = ± .01	AJB	BOARD AND BATTEN PROFILE
	2	R-10313	11/19/25	AJB	.XXX = ± .005	ECR NO. NONE	
						FRACTION = ± 1/32"	RELEASED BY
					ANGLE = ± 1/2°	AJB	PART NUMBER
						RELEASE DATE	BB7-750P
						9/13/2022	SHEET
							1 OF 1
							REVISION
							2